

INTERNATIONAL® OTELSAN

Otelsan Buklet Malzemeleri Otel Ekipmanları ve Mimarlık Hizmetleri A.Ş.

www.otelsan.com.tr



HOUSEKEEPING
EQUIPMENTS



FRONT OFFICE
EQUIPMENTS



BANQUET & MEETING
EQUIPMENTS



RESTAURANT
EQUIPMENTS

INDEX

INTERNATIONAL®
OTELSAN
Otelsan Buklet Malzemeleri Otel Ekipmanları ve Mimarlık Hizmetleri A.Ş.



01 HOUSEKEEPING 12-33
EQUIPMENTS Pages

34-43 FRONT OFFICE
Pages EQUIPMENTS **02**



03 BANQUET & MEETING 44-87
EQUIPMENTS Pages

88-131 RESTAURANT
Pages EQUIPMENTS **04**



www.otelsan.com.tr

INTERNATIONAL OTELSAN®

Otelsan Buklet Malzemeleri Otel Ekipmanları ve Mimarlık Hizmetleri A.Ş.

About Us

Founded in 2000, Otelsan is a leading provider of hotel equipment and professional industrial solutions, combining quality, durability, and functionality. With strong expertise in the hospitality sector, we deliver turnkey hotel projects—from concept to installation—through efficient, safe, and fully coordinated processes. Exporting to over 80 countries, Otelsan is a trusted partner both locally and globally.

Vision

To become a globally preferred brand in hotel equipment and turnkey projects through innovation, sustainability, and customer-focused solutions.

Mission

To enhance operational efficiency and functionality by delivering fully integrated, high-standard solutions, while building long-term, reliable partnerships worldwide.

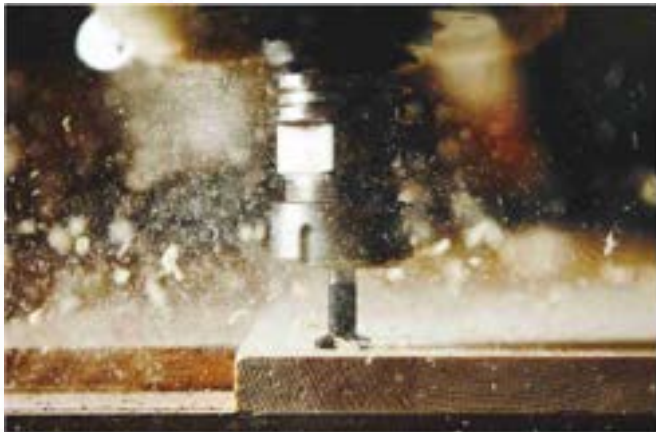

HOW DO WE OPERATE?

At Otelsan, we provide practical and efficient solutions tailored to the needs of the service industry, ensuring timely delivery and maximum convenience. Our foldable and nestable designs allow easy storage and long-term usability, making them highly preferred.

We prioritize durability, aesthetics, and user-friendly design in all our processes. By closely following international standards and industry developments, we deliver high-quality and innovative solutions to our customers.

In addition to our wide product range, we offer project-based design and implementation services, creating elegant and functional spaces. Through our sales and after-sales support, we establish long-term and reliable partnerships.

We also assist our customers in determining the exact quantities needed during purchasing processes, helping to avoid unnecessary costs.

WHAT DO WE OFFER?

Our product categories include:

- Housekeeping Equipment
- Front Office Equipment
- Banquet & Meeting Equipment
- Restaurant Equipment

OTELSAN GLOBAL

With over 25 years of experience in the manufacturing and hotel equipment industry, we are proud to have reached a point where we export our products to **more than 80 countries** worldwide.



80+
COUNTRIES
WORLDWIDE

































25+
YEARS OF
EXPERIENCE



YOUR TRUSTED
SOLUTION PARTNER

REFERENCES

 <p>THE MARMARA</p>	 <p>RENAISSANCE HOTELS</p>	 <p>ADDRESS HOTELS + RESORTS</p>	 <p>CROWNE PLAZA HOTELS & RESORTS</p>	 <p>LORD'S PALACE Hotels + SPA + Casino</p>	 <p>Marriott</p>
 <p>Hilton HOTELS & RESORTS</p>	 <p>Le MERIDIEN</p>	 <p>Fairmont QUASAR ISTANBUL</p>	 <p>THEHOUSE HOTEL</p>	 <p>POINT BARBAROS</p>	 <p>RAMADA</p>
 <p>FOUR SEASONS HOTEL</p>	 <p>AVANTGARDE COLLECTION</p>	 <p>CONRAD ISTANBUL BOSPHORUS</p>	 <p>divan</p>	 <p>ST REGIS</p>	 <p>swissôtel Hotels & Resorts</p>
 <p>Mercure HOTELS</p>	 <p>Radisson</p>	 <p>Çırağan Palace Kempinski ISTANBUL</p>	 <p>MERT Park Hotel & Casino</p>	 <p>MIRACLE ISTANBUL ASIA</p>	 <p>MÖVENPICK HOTELS & RESORTS</p>
 <p>THE RITZ-CARLTON®</p>	 <p>Sheraton</p>	 <p>NOVOTEL HOTELS, SUITES & RESORTS</p>	 <p>DOUBLETREE BY HILTON</p>	 <p>RIVOS HOTELS</p>	 <p>CRATOS</p>

WHY OTELSAN?

Industry Expertise

- Over 25 years of experience in the sector and project development
- Strong ability to understand and respond to customer needs

Partnership Approach

- Focus on building long-term and sustainable partnerships

Quality Standards

- Durability and functionality are prioritized in all designs
- Ensuring long-term and reliable use of all products

Wide Product Range

- More than 2,000 HoReCa product solutions

Warranty

- All products are covered by a 2-year warranty against manufacturing defects

Superior Customer Service

- Fast and effective response to inquiries
- Professional and timely resolution of any issues



INTERNATIONAL®
OTELSAN
Otelan Buklet Malzemeleri Otel Ekipmanları ve Mimarlık Hizmetleri A.Ş.



HOUSEKEEPING
EQUIPMENTS

CHAMBERMAID'S TROLLEYS

PREMIUM SERIE



AESTHETICS DYNAMIC

Otelsan Premium Series chambermaid trolleys feature a robust and modular construction combined with an elegant and aesthetic design. Equipped with an all-round bumper profile, they effectively protect corridor walls and surfaces from potential damage during operation.

The centrally positioned fifth wheel ensures excellent maneuverability, allowing the trolley to move smoothly and rotate 360° around its own axis for maximum control in tight spaces. Height-adjustable shelves provide convenient storage for items such as towels, bed linens, and pillowcases, ensuring efficient organization during housekeeping operations.

Specially designed wheels offer superior mobility and smooth performance, even on carpeted flooring. Developed with Otelsan quality standards, the Premium Series delivers durability, functionality, and ease of use for professional hospitality environments.



1450

CHAMBERMAID'S TROLLEY

- » Electrostatic powder coated structure
- » Easy to manoeuvre with 5th castor
- » All-round bumper profile
- » Adjustable shelves
- » Lid for garbage with clamp fastening
- » A separator on upper shelf
- » 2 easy removable bags
- » Folding side sections for space-saving storage
- » Ø200 mm 4 swivel polyamide castors, 5th castor in the center with rubber tread

Dimensions W:59 L:99/163 H:128 cm

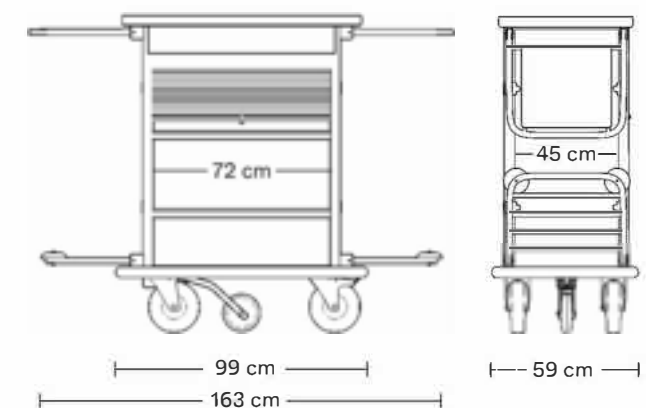



1450 L
CHAMBERMAID'S TROLLEY
(With Top Lid)

- » Electrostatic powder coated structure
- » Lockable top lid
- » Easy to maneuver with 5th castor
- » All-round bumper profile
- » Adjustable shelves
- » Lid for garbage with clamp fastening
- » A separator on upper shelf
- » 2 easy removable bags
- » Folding side sections for space-saving storage
- » Ø200 mm 4 swivel polyamide castors, 5th castor in the center with rubber tread

Dimensions W:59 L:99/163 H:128 cm



OPTIONALS



14-YD
Ø200 mm Foam Filled Wheel
(Ideal for hard and uneven floors)



14-ST
Lockable plastic roller panel



14-UK
Lockable top lid with spring hinge



14-CKR
Lid for garbage with clamp fastening
(Double partition for waste)



14-YT
Extra linen bags



14-AK
Removable trolley with waste bag



14-MK
Mop holder



1460 S

MINIBAR TROLLEY
(With 3 Drawers)

- » Electrostatic powder coated structure
- » 3 stable drawers (50 kg carriage capacity)
- » Lockable plastic roller panel
- » Easy to maneuver with 5th castor
- » All-round bumper profile
- » Ø 200 mm 4 swivel polyamide castors, 5th castor in the center with rubber tread

Dimensions W:59 L:99 H:128 cm

1460

MINIBAR TROLLEY
(With Shelves)

- » Electrostatic powder coated structure
- » Adjustable shelves
- » Lockable plastic roller panel
- » Easy to maneuver with 5th castor
- » All-round bumper profile
- » Ø200 mm 4 swivel polyamide castors, 5th castor in the center with rubber tread

Dimensions W:59 L:99 H:128 cm

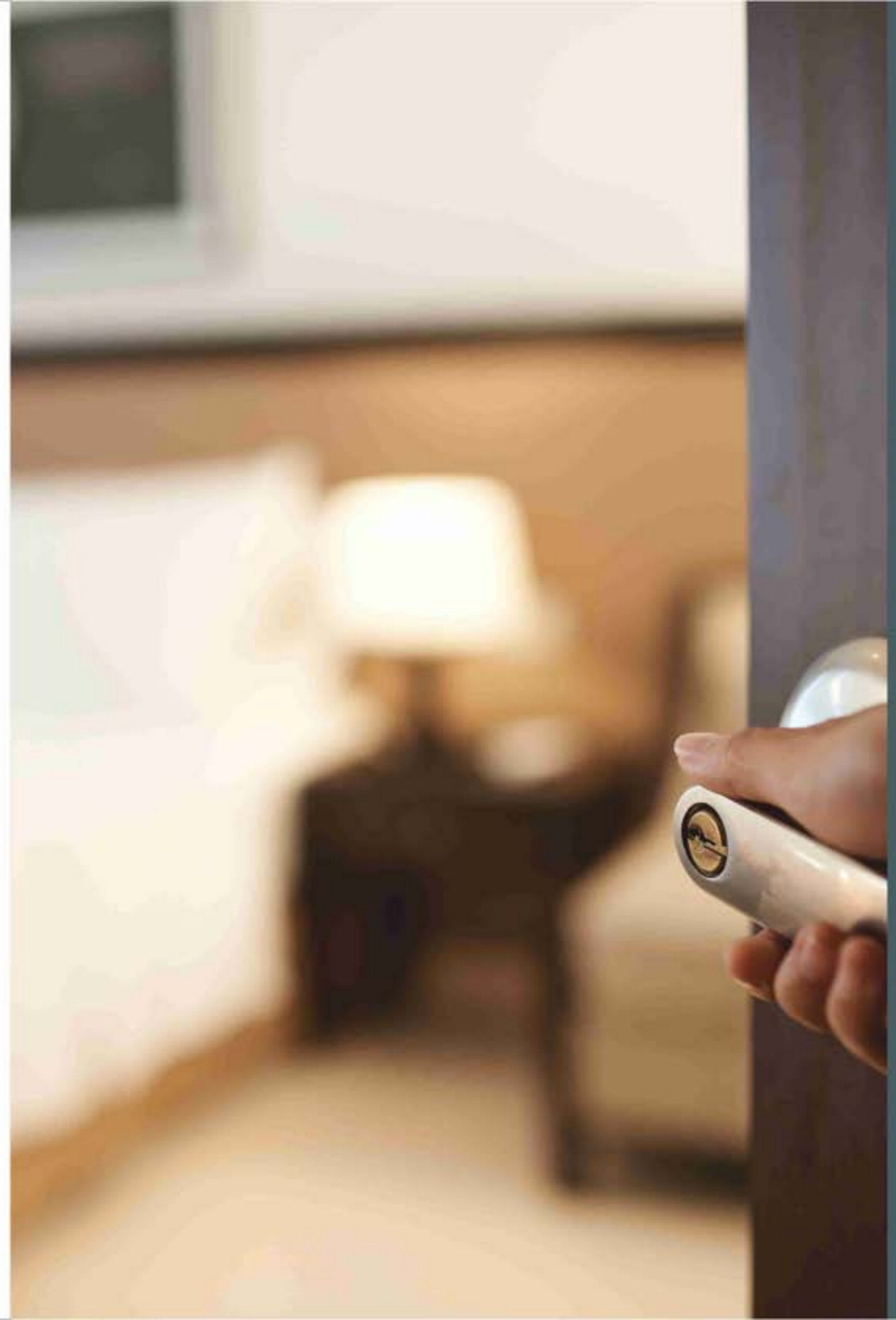
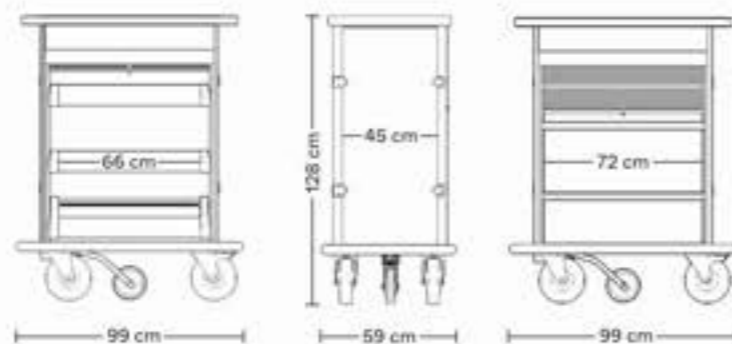

CHAMBERMAID'S TROLLEYS

DYNAMIC SERIE



1415

CHAMBERMAID'S TROLLEY

- » Electrostatic powder coated profile structure
- » All-round bumper profile
- » Lid for garbage with clamp fastening
- » A separator on upper shelf
- » 2 easy removable bags
- » Folding side sections for space-saving storage
- » 4 swivel casters, 2 with brakes (Ø150 mm Polyamide)

Dimensions W:61 L:97/147 H:132 cm

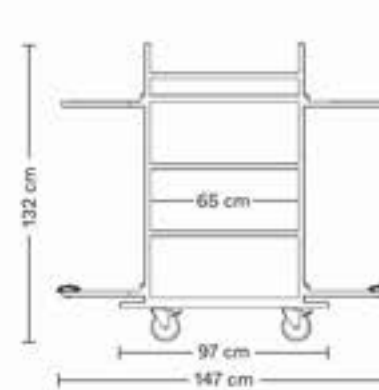

SPECIAL FEATURES



All-round bumper profile



Lid for garbage with clamp fastening



Ideal for carpet floors
Ø150 mm polyamide castors



1416

CHAMBERMAID'S TROLLEY (Light)

- » Electrostatic powder coated profile structure
- » Durable, polyester fabric covered body
- » A separator on upper shelf
- » 2 easy removable bags
- » Folding side sections for space-saving storage
- » 4 swivel casters, 2 with brakes

Dimensions W:58 L:92/147 H:132 cm



1410

CHAMBERMAID'S TROLLEY

- » Electrostatic powder coated profile structure
- » A separator on upper shelf
- » 2 easy removable bags
- » Folding side sections for space-saving storage
- » 4 swivel casters, 2 with brakes

Dimensions W:58 L:92/147 H:132 cm

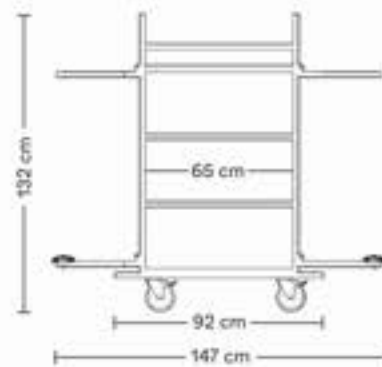
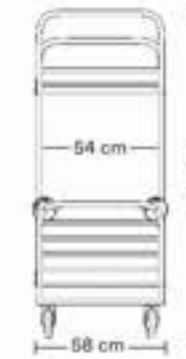
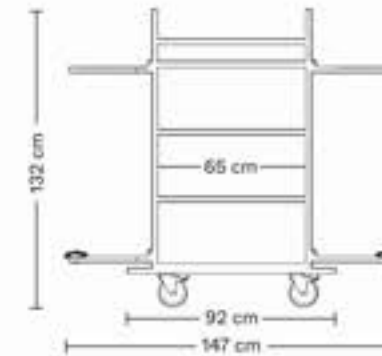

1410 K

CHAMBERMAID'S TROLLEY (With Door)

- » Electrostatic powder coated profile structure
- » A separator on upper shelf
- » Two linen bag holders
- » 2 easy removable bags
- » Folding side sections for space-saving storage
- » Door with lock
- » 4 swivel casters, 2 with brakes

Dimensions E:58 B:92/147 Y:132 cm





1411
CHAMBERMAID'S TROLLEY
(Slim)

- » Electrostatic powder coated profile structure
- » A separator on upper shelf
- » 2 easy removable bags
- » Folding side sections for space-saving storage
- » 4 swivel casters, 2 with brakes

Dimensions W:60 L:72/134 H:132 cm

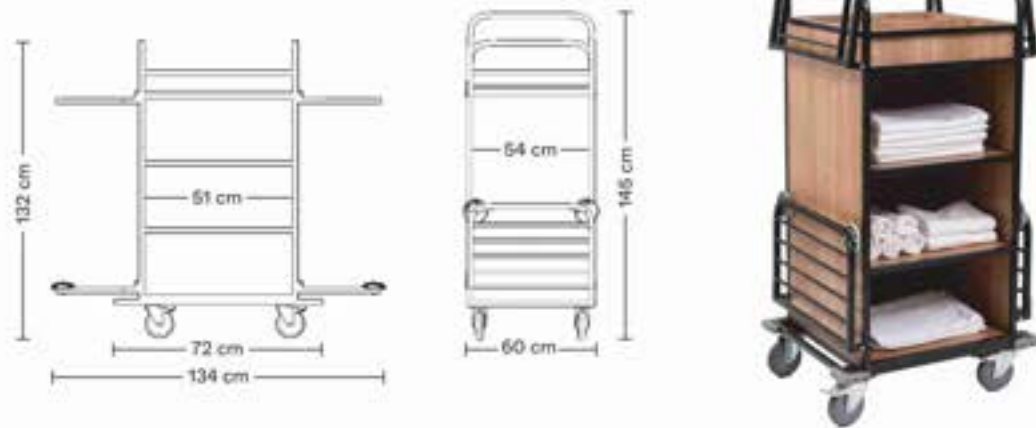

801
MINIBAR TROLLEY

- » Electrostatic powder coated profile structure
- » Mdf/ply surface
- » Bumpers
- » Door that can be locked up
- » 4 swivel casters, 2 with brakes

Dimensions W:60 L:90 H:132 cm

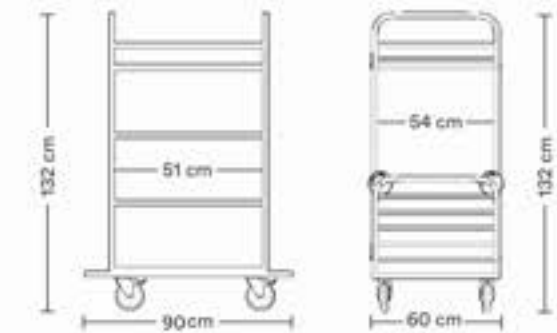

1415/1416/1410/1410K/1411 OPTIONS



805
TABLE OUT TROLLEY

- » Electrostatic powder coated profile structure
- » Mdf/ply surface
- » Bumpers
- » 5 shelves (10 pieces of 40x60 cm tray capacity)
- » 4 swivel casters, 2 with brakes

Dimensions W:68 L:91 H:146 cm

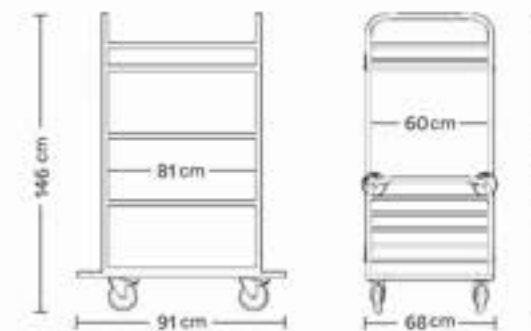



1470
CHAMBERMAID'S TROLLEY

- » Plastic ABS body (grey)
- » Electrostatic powder coated tube structure
- » 5 pieces inside drawer
- » Two linen bags holders
- » Back and both sides are fabric canvas covered
- » 2 fixed, 2 swivel casters with break.

Dimensions W:61 L:112/175 H:148 cm



1570
MOP TROLLEY

- » Electrostatic powder coated tube structure
- » Removable linen bag
- » Two buckets and a press
- » 4 swivel casters, 2 with brakes

Dimensions W:45 L:98 H:105 cm

1475
CHAMBERMAID'S TROLLEY

- » Plastic ABS body (grey)
- » Electrostatic powder coated tube structure
- » 3 pieces inside drawer
- » Linen bag holders
- » Back and both sides are fabric canvas covered
- » 2 fixed, 2 swivel casters with break.

Dimensions W:61 L:112 H:148 cm



1575
MOPPING TROLLEY

- » 2 buckets 1 mops press



1485
CLEANING TROLLEY

- » Plastic ABS body (grey)
- » Electrostatic powder coated tube structure
- » 2 fixed, 2 swivel casters with break

Dimensions W:62 L:140 H:107 cm



1590
GARBAGE CONTAINER

- » 120 lt capacity
- Dimensions W:54 L:50 H:92 cm



1595
GARBAGE CONTAINER

- » 240 lt capacity
- Dimensions W:72 L:57 H:110 cm

LAUNDRY TROLLEYS



1531
LAUNDRY TROLLEY

- » Electrostatic powder coated tube structure
- » Removable linen bag
- » 4 swivel casters , 2 with brakes

Dimensions W:60 L:90 H:90 cm

1532
LAUNDRY TROLLEY

- » Electrostatic powder coated tube structure
- » Two separate removable linen bags
- » 4 swivel casters, 2 with breaks

Dimensions W:53 L:96 H:104 cm



1535
LAUNDRY TROLLEY

- » Electrostatic powder coated tube structure
- » Removable linen bag
- » 4 swivel casters , 2 with brakes

Dimensions W:53 L:53 H:104 cm

1540
GARMENT RAIL

- » Electrostatic powder coated tube structure
- » 4 swivel casters, 2 with breaks

Dimensions W:67 L:152 H:175 cm





1510 P
FOLDABLE LAUNDRY TROLLEY

- » Stainless steel tube structure
- » Foldable for storage
- » Removable linen bag
- » 4 swivel casters , 2 with brakes

Dimensions W:54 L:50 H:92 cm

1550
PLASTIC LAUNDRY TROLLEY

- » 280 lt capacity
- » Electrostatic powder coated bottom chasiss
- » 4 polyamid casters

Dimensions W:67 L:90 H:80 cm



1551
PLASTIC LAUNDRY TROLLEY

- » 500 lt capacity
- » Electrostatic powder coated bottom chasiss
- » 4 polyamid casters

Dimensions W:67 L:90 H:80 cm

1520
FOLDABLE LAUNDRY TROLLEY

- » Electrostatic powder coated tube structure
- » Foldable for storage
- » Removable linen bag
- » 4 swivel casters , 2 with brakes

Dimensions W:54 L:50 H:92 cm



1560
PORTABLE WIRE SHELF

- » AISI 304 Stainless steel structure

Dimensions W:36/46/53/61/76 cm
L:91/107/122/137/152/183 cm
H:137/150/160/183/216/244 cm



1555 P
LAUNDRY TROLLEY

- » AISI 304 stainless steel structure
- » 4 swivel casters

Dimensions W:61 L:61 H:75 cm

1555
LAUNDRY TROLLEY

- » Plastic coated structure
- » 4 swivel casters

Dimensions W:55 L:67 H:70 cm



1580
LUNDRY TROLLEY

- » Electrostatic powder coated tube structure
- » 4 swivel casters, 2 with breaks

Dimensions W:92 L:58 H:177 cm





1665

FOLDABLE CRIB

- » Wooden, foldable body
- » Bed is include in price

Dimensions W:32/70 L:102 H:83 cm



1667

FOLDABLE EXTRA BED

- » Electrostatic powder coated structure
- » 15 cm spring bed
- » 4 swivel casters

Dimensions W:90 L:200 H:45 cm



1666

FOLDABLE CRIB

- » Electrostatic powder coated tube structure
- » 60x120 cm baby bed
- » Washable cover



1668

FOLDABLE EXTRA BED

- » Electrostatic powder coated structure
- » 22 cm spring bed
- » 4 swivel casters

Dimensions W:90 L:190 H:45 cm





INTERNATIONAL[®]
OTELSAN
Otelsoan Buklet Malzemeleri Otel Ekipmanları ve Mimarlık Hizmetleri A.Ş.



FRONT OFFICE
EQUIPMENTS

LUGGAGE TROLLEYS



1340
LUGGAGE TROLLEY

- » Polished Gold PVD coated AISI 304 stainless steel tube structure
- » Carpet covers the lower platform
- » All-round bumper profile
- » 4 casters, 2 with brakes

Dimensions W:65 L:105 H:193 cm

1340 P
LUGGAGE TROLLEY

- » AISI 304 Stainless steel tube structure
- » Carpet covers the lower platform
- » All-round bumper profile
- » 4 casters, 2 with brakes

Dimensions W:65 L:105 H:193 cm



1341 P
LUGGAGE TROLLEY

- » AISI 304 Stainless steel tube structure
- » Carpet covers the lower platform
- » All-round bumper profile
- » 4 casters, 2 with brakes

Dimensions W:65 L:105 H:193 cm





1342 P

LUGGAGE TROLLEY

- » AISI 304 Stainless steel tube structure
- » Carpet covers the lower platform
- » All-round bumper profile
- » 4 casters, 2 with brakes

Dimensions W:65 L:105 H:190 cm



1343 P

LUGGAGE TROLLEY

- » AISI 304 Stainless steel tube structure
- » Carpet covers the lower platform
- » All-round bumper profile
- » 4 casters, 2 with brakes

Dimensions W:65 L:105 H:193 cm



1345 P

LUGGAGE TROLLEY

- » AISI 304 Stainless steel tube structure
- » Carpet covers the lower platform
- » All-round bumper profile
- » 4 casters, 2 with brakes

Dimensions W:65 L:105 H:191 cm

METAL FINISH OPTIONS



SURFACE OPTIONS



WHEEL OPTIONS



14-YD
Ø200 mm Foam Filled Wheel
(Ideal for hard and uneven floors)



13-PER
Ø200 mm Silent, Elastic Rubber Tread
(Can be used many types of floor)

EXTRA OPTION



13-VT
Cover for handles



13-CV PROTECTIVE COVER

- » Various colours available
- » Optional logo printing

1320

LUGGAGE TROLLEY
(Electrostatic Powder Coated)



1330

LUGGAGE TROLLEY
(Polished GOLD PVD)



1330 P

LUGGAGE TROLLEY
(AISI 304 Stainless Steel)



- » Metal tube structure
- » Carpet covers the platform
- » 2 fixed wheels

Dimensions W:34/83 L:65 H:118 cm

1360

ROOM CHANGE TROLLEY

- » AISI 304 stainless steel structure
- » 4 casters, 2 with brakes

Dimensions W:46 L:91 H:176 cm

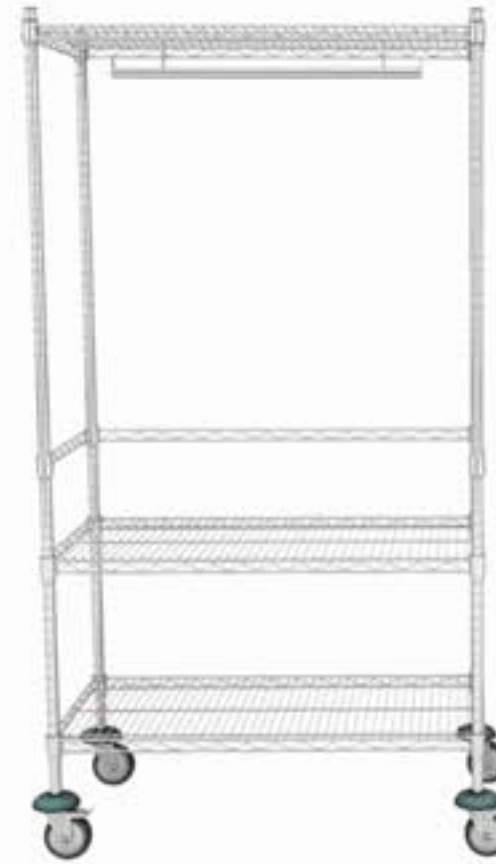

1870

LUGGAGE RACK
(Wooden)

Dimensions W:44 L:61 H:53 cm



1871

LUGGAGE RACK
(AISI 304 Stainless Steel)

Dimensions W:47 L:59 H:61 cm



1872

LUGGAGE RACK
(Electrostatic Powder Coated)

Dimensions W:47 L:59 H:61 cm



1870 A

LUGGAGE RACK WITH
BACKREST
(Wooden)

Dimensions W:46 L:61 H:62 cm



1871 A

LUGGAGE RACK WITH
BACKREST
(AISI 304 Stainless Steel)

Dimensions W:47 L:59 H:70 cm



1872 A

LUGGAGE RACK WITH
BACKREST
(Electrostatic Powder Coated)

Dimensions W:47 L:59 H:70 cm



1810 P

BARRIER
(Stainless Steel)

Dimensions Ø:32 H:104 cm

1810

BARRIER
(Gold Titanium)

Dimensions Ø:32 H:104 cm

1811 A

ROPE

Dimensions 140 cm



1813

RETRACTABLE
BARRIER
(Stainless Steel)

Dimensions Ø:34 H:95 cm



1885

ASHTRAY
(Brass)

1886

ASHTRAY
(Stainless Steel)



1912

TRASH BIN
(Stainless Steel)



1913

TRASH BIN
(Leatherette Covered)



1896

TRASH BIN
(Stainless Steel)



1895

TRASH BIN
(Stainless Steel)



1841

SIGN BOARD

- » Wooden body
- » Plexiglass, revolving frame (A4)

Dimensions W:27 L:52 H:102 cm



1840

SIGN BOARD

- » AISI 304 Stainless steel pipe body and the base
- » Plexiglass, revolving frame (A4)

Dimensions Ø:38 H:100 cm



1842

SIGN BOARD

- » AISI 304 Stainless steel pipe body and the base
- » Plexiglass frame (A4)

Dimensions Ø:30 H:120 cm



1875

SHOE SHINNER

- » Black and brown brush

Dimensions W:55 L:34,5 H:87 cm



**INTERNATIONAL
OTELSAN**
Otelisan Buklet Malzemeleri Otel Ekipmanları ve Mimarlık Hizmetleri A.Ş.



BANQUET &
MEETING
EQUIPMENTS

MEETING TABLES



FUNCTIONAL MODULAR

Otelsan meeting tables are designed to adapt seamlessly to various meeting room layouts, offering practical and efficient setup thanks to their folding leg system. The specially engineered locking mechanism ensures that meeting arrangements can be prepared quickly, safely, and effortlessly.

In addition to their functional structure, these tables enhance interior aesthetics with a wide range of leg and tabletop color options, providing a modern and elegant appearance. Manufactured with Otelsan quality, these meeting tables are an ideal solution for professional environments where fast and efficient room setup is essential.



Stainless steel,
standart foldable leg



Electrostatic powder coated,
standart foldable leg



Stainless steel,
T model foldable leg



Electrostatic powder coated,
T model foldable leg



1600 TP
MEETING TABLE / T MODEL LEG
(Stainless Steel)



Standard Dimensions

- 45 x 120 cm
- 45 x 140 cm
- 45 x 160 cm
- 45 x 180 cm
- 70 x 120 cm
- 70 x 140 cm
- 70 x 160 cm
- 70 x 180 cm

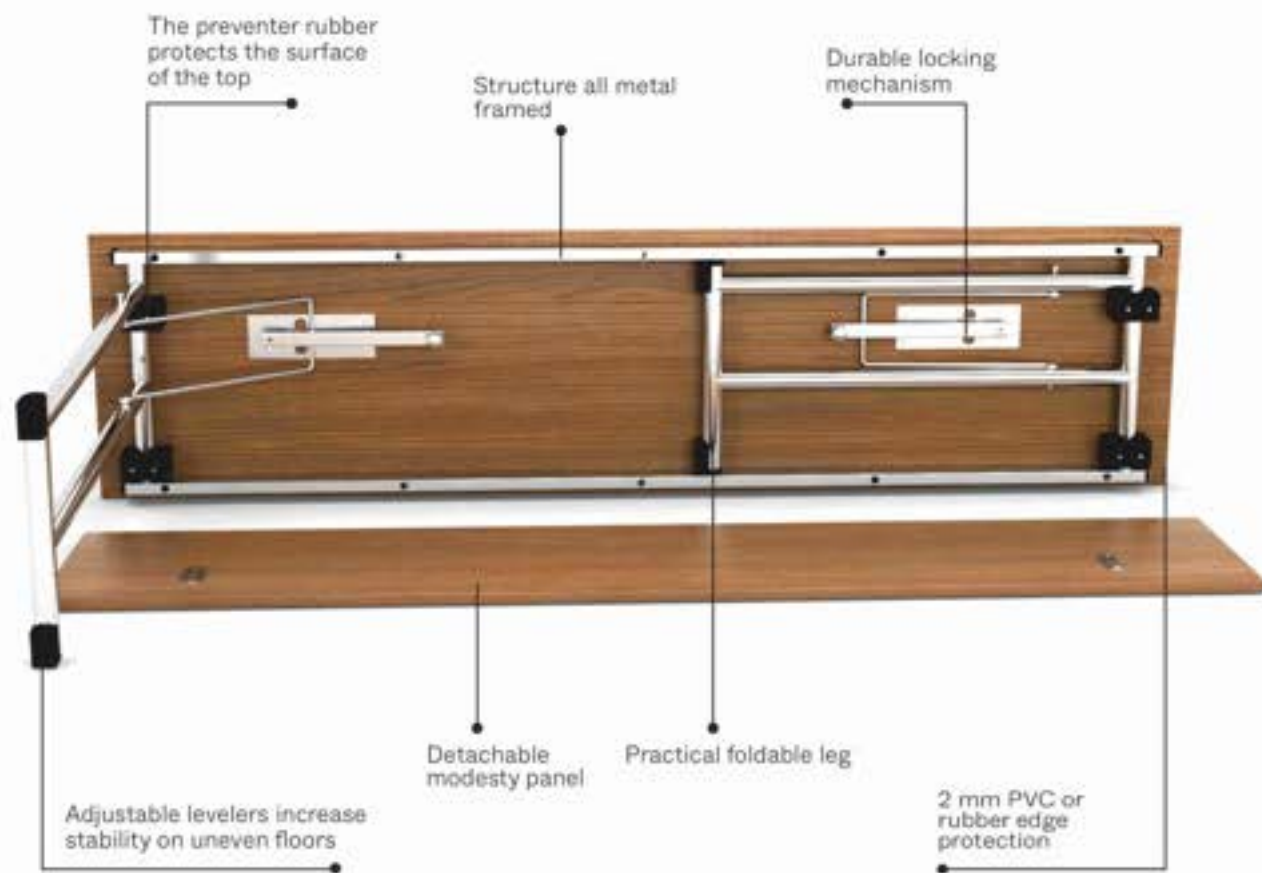

The preventer rubber protects the surface of the top

Structure all metal framed

Durable locking mechanism

Detachable modesty panel

Practical foldable leg

2 mm PVC or rubber edge protection

Adjustable levelers increase stability on uneven floors



1600 TB
MEETING TABLE / T MODEL LEG
(Electrostatic Powder Coated)

Color of the legs can be changed according with your decoration theme



15 pcs. stackable



1600 SP
MEETING TABLE / STANDART LEG
(Stainless Steel)



Standard Dimensions

- 45 x 120 cm
- 45 x 140 cm
- 45 x 160 cm
- 45 x 180 cm
- 70 x 120 cm
- 70 x 140 cm
- 70 x 160 cm
- 70 x 180 cm

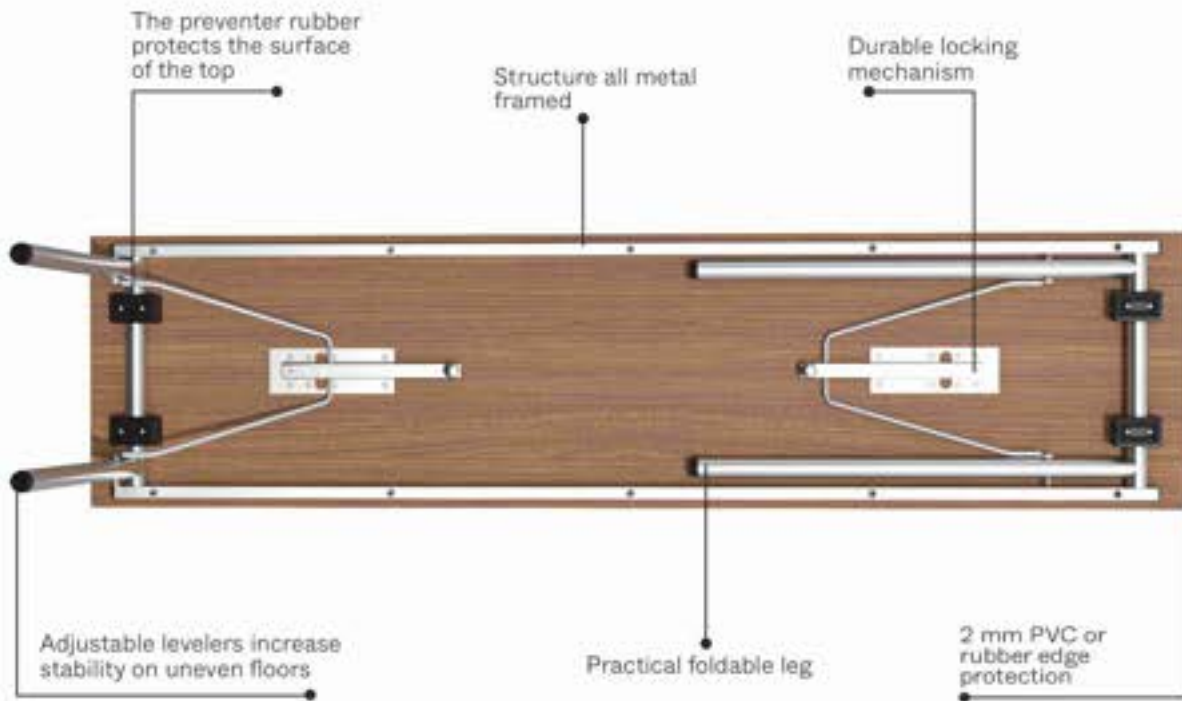

1600 SB
MEETING TABLE / STANDART LEG
(Electrostatic Powder Coated)



15 pcs. stackable

1600 YD

MEETING TABLE / HALF ROUND



Standard Dimensions
70 x 140 cm
80 x 180 cm

1600 AY

MEETING TABLE / 90° SEGMENT



4 required to make complete
Ø 260 cm circle
260 cm OD
120 cm ID



• 2 mm PVC edge

• Rubber edge

LAYOUT OPTIONS

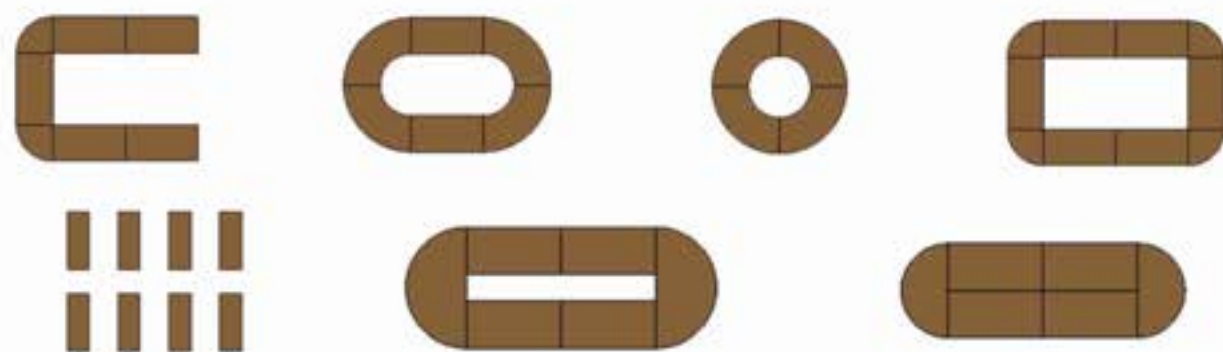

1646

MEETING TABLE TROLLEY

- » Electrostatic powder coated tube structure
- » 10 tables and 10 modesty panel capacity
- » Swivel bars separate the tables whilst stored
- » Carpet covers the platform
- » 4 casters, 2 with brakes

Dimensions W:67 L:128 H:123 cm
(Dimensions may change depending on table size)

1645 D

RECTANGLE TABLE TROLLEY

- » Electrostatic powder coated tube structure
- » 10 tables capacity
- » Carpet covers the platform
- » 4 casters, 2 with brakes

Dimensions W:85 L:200 H:90 cm
(Dimensions may change depending on table size)



POWER CONNECTIVE TABLES



INNOVATIVE CONNECTIVITY

Otelsan tables equipped with an integrated socket system provide the necessary power supply for laptops, tablets, and other devices during meetings. Electrical energy can be distributed from a single connection point and transferred seamlessly between tables, helping to eliminate cable clutter on the floor and maintain a clean, organized meeting environment.

Thanks to additional modular components, multiple meeting setups can be arranged quickly and efficiently by a single user. The foldable tabletop and specially designed nesting structure optimize storage efficiency, saving valuable space in warehouses and storage areas.

Featuring a wheeled construction, Otelsan folding tables with socket systems ensure easy installation, effortless transportation, and practical storage, making them an ideal solution for dynamic and flexible meeting spaces.





1609
POWER CONNECTIVE TABLE



Standard Dimensions
70 x 120 cm
70 x 140 cm
70 x 160 cm
70 x 180 cm



SOCKET BOX OPTIONS



1609 LK
LEGRAND
SOCKET BOX
» 2 power socket



1609 LB
LEGRAND
SOCKET BOX
» 2 power socket
» 2 USB charging



1609 YP
SOCKET BOX
» 2 power socket
» 2 USB charging



1609 YPW
SOCKET BOX
» 2 power socket
» 2 USB charging
» 1 wireless charging



1609 A
MEETING TABLE / TRAPEZOIDAL



1609 YD
MEETING TABLE /
HALF ROUND

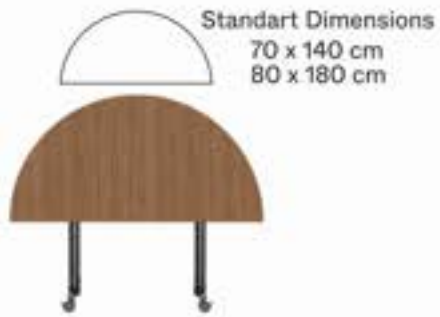

1609 AY
MEETING TABLE /
90° SEGMENT



LAYOUT OPTIONS

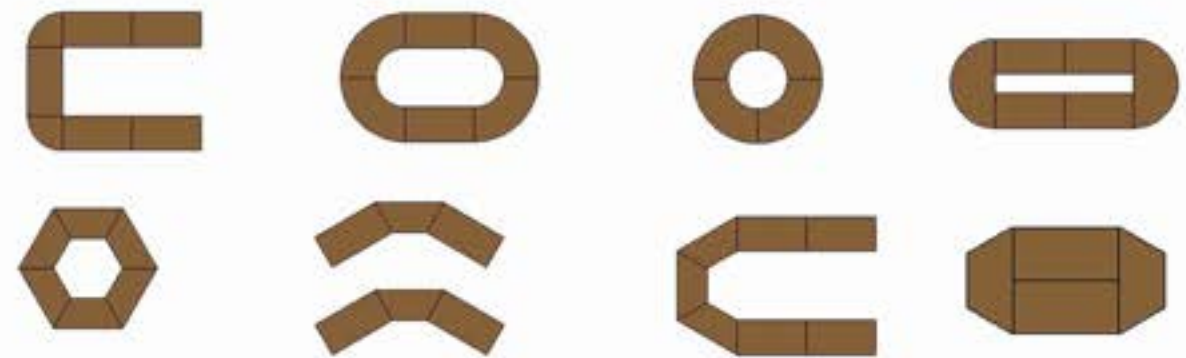

BANQUET TABLES



STRONG PRACTICAL

Otelsan banquet tables are designed for quick, safe, and efficient setup in events such as weddings and large-scale gatherings. The special double-lock mechanism ensures maximum stability during use while allowing the tables to be easily folded and stored when not needed.

Built with an industrial-grade leg system, these tables are engineered for long-term durability and reliable performance over many years of use. The optionally available aluminum edge provides enhanced protection for the tabletop, ensuring resistance against impacts and wear.

Integrated protective rubber components within the leg system prevent scratches and damage to stacked table surfaces, maintaining product quality during storage and transport. Every detail of the design has been carefully considered to support long-lasting, trouble-free use, and the entire leg system is backed by a 5-year warranty, reflecting Otelsan's commitment to quality and reliability.





1635
BANQUET TABLE

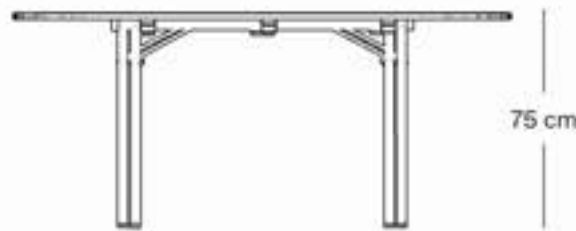

75 cm

Standart Dimensions
 Ø 120 cm (4 People)
 Ø 140 cm (6 People)
 Ø 160 cm (8 People)
 Ø 180 cm (10 People)

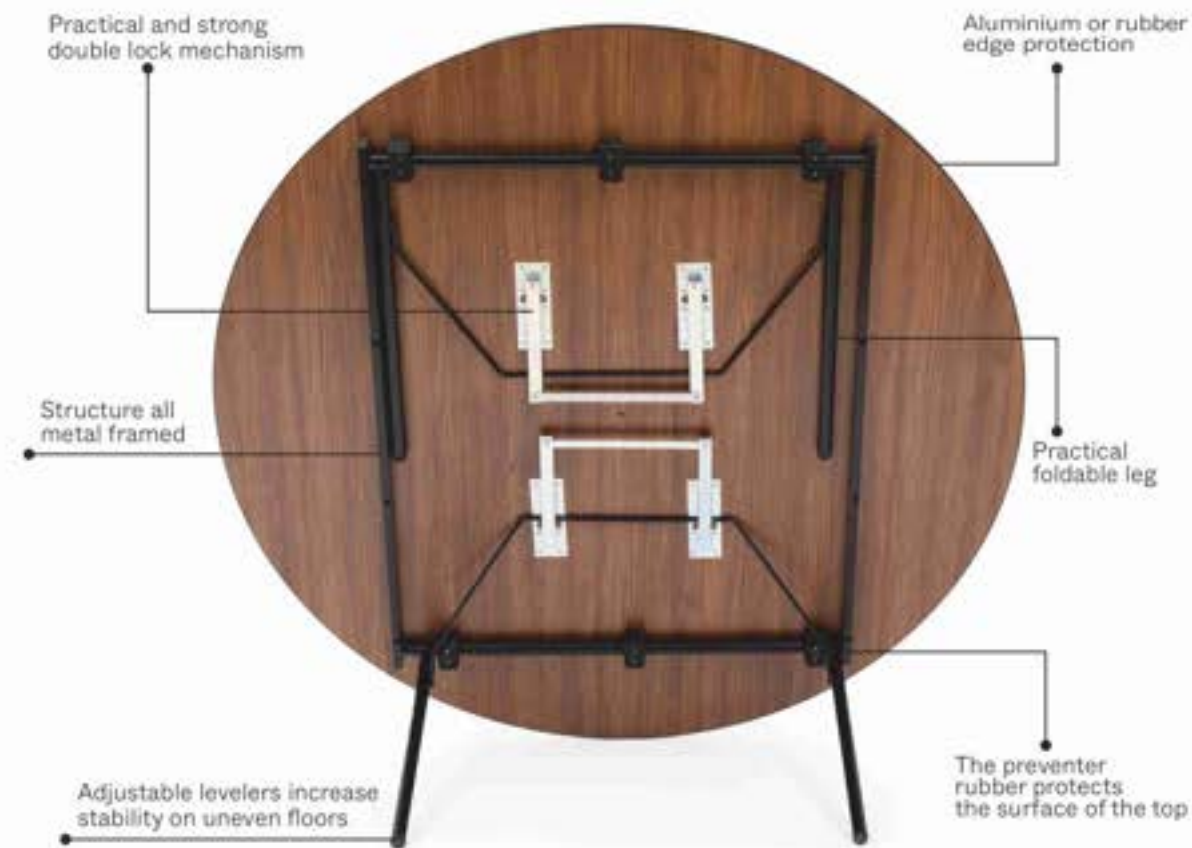

Practical and strong double lock mechanism

Aluminium or rubber edge protection

Structure all metal framed

Practical foldable leg

Adjustable levelers increase stability on uneven floors

The preventer rubber protects the surface of the top



15 pcs. stackable

1645
ROUND TABLE TROLLEY

- » Electrostatic powder coated tube structure
- » 7 table capacity
- » Carpet covers the platform
- » 4 casters, 2 with brakes

Dimensions W:70 L:160 H:107 cm





1640
BANQUET TABLE



Standart Dimensions

- 45 x 120 cm
- 45 x 140 cm
- 45 x 160 cm
- 45 x 180 cm
- 80 x 120 cm
- 80 x 140 cm
- 80 x 160 cm
- 80 x 180 cm

Practical and strong lock mechanism



Aluminium or rubber edge protection

Adjustable levelers increase stability on uneven floors

Structure all metal framed

Practical foldable leg

The preventer rubber protects the surface of the top



15 pcs. stackable

ROUND AND RECTANGLE BANQUET TABLE EDGE PROTECTION OPTIONS



Aluminium Edge
1635 LA (Round Table)
1640 LA (Rectangle Table)



Rubber Edge
1635 A (Round Table)
1640 A (Rectangle Table)

ROUND AND RECTANGLE BANQUET TABLE TOP OPTIONS



Melamine faced MDF



2 mm Hygienic Vinyl Covered MDF



Mat Covered MDF

BANQUET CHAIRS



1622

BANQUET CHAIR
(Aluminum)

- » 25 x 25 x 2 mm aluminium structure
- » Electrostatic powder coated
- » 600 gr. Cold cast polyurethane sponge seat

Dimensions W:45 L:59,5 H:48/93,5 cm

1632 ES

BANQUET CHAIR
(Flexible Back)

- » 25 x 25 x 2 mm aluminium structure
- » Electrostatic powder coated
- » Flexible back
- » 600 gr. Cold cast polyurethane sponge seat

Dimensions W:45 L:61 H:48/90 cm





FAST AND SAFE INSTALLATION

Otelsan folding stage systems are designed for use as reliable stage platforms at weddings, concerts, and various events. Engineered with high load-bearing capacity, they are strong enough to safely support orchestras, musical instruments, and professional stage equipment.

One of the key features that distinguishes this system is its ability to be installed quickly and safely by a single person, significantly improving setup efficiency. The integrated stage connector mechanism securely links individual podium units, allowing the creation of large, stable stage surfaces that remain firmly connected throughout the event.

With its durable structure and practical design, the Otelsan folding stage system offers a flexible, safe, and professional staging solution for dynamic event environments.



PORTABLE STAGE





1695

STAGE
(Foldable & Lift support)

- » Folding stage is designed to be opened and closed by one person
- » Easy folding by gas springs
- » Safety installation by double handles
- » 40-50-60 cm height adjustable
- » Changing heights is simple with our special lock system
- » Carpet covered surface
- » Connecting locks for the next podium
- » 4 Wheels

Dimensions W:122 L:244 H:40/50/60 cm

1695 B

STAGE
(Foldable & Lift support/ Big)

Dimensions W:183 L:244 H:40/50/60 cm



1696

STAGE STEP

- » Electrostatic powder coated profile structure
- » Carpet covers the platform

Dimensions W:54 L:100 H:40 cm

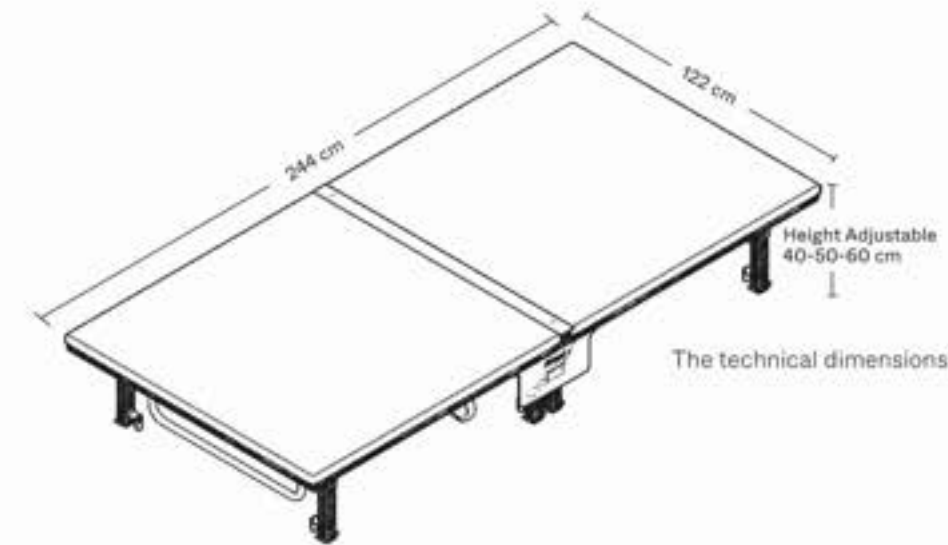
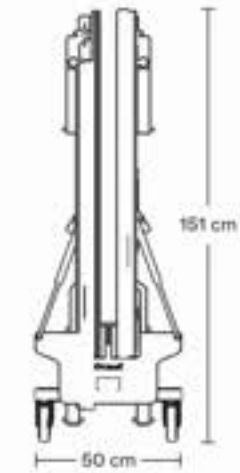
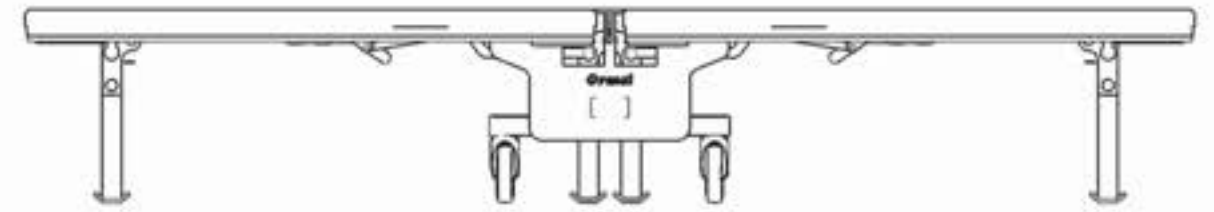

The technical dimensions of 1695.

SURFACE OPTIONS



Black Carpet



Gray Carpet

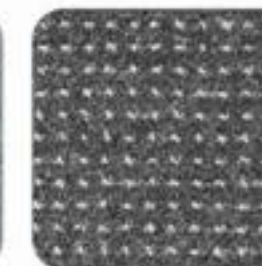

Gray Spotted Carpet



Anti Slip Hexa Birch



1690
DANCE FLOOR

- » Aluminium frame
- » Laminate surface

Dimensions W:85 L:85 H:3 cm



1691
DANCE FLOOR RAMP

- » Aluminium



1697
DANCE FLOOR TROLLEY

- » Electrostatic powder coated tube structure
- » Carpet covers platform
- » 4 casters, 2 with break

Dimensions W:70 L:125 H:102 cm



1950
SEPARATOR
(Foldable)

- » Electrostatic powder coated profile foldable structure
- » Plywood is covered with fabric surface
- » Casters with break

Dimensions W:35 L:235 H:190 cm



1940
SEPARATOR

- » Electrostatic powder coated profile structure
- » Mdf/lam surface
- » Casters with break

Dimensions W:55 L:78 H:190 cm



1542
LINEN TROLLEY

- » Electrostatic powder coated tube structure
- » Carpet covered top
- » 4 swivel casters, 2 with breaks

Dimensions W:65 L:150 H:150 cm



750
LECTERN

- » Height adjustable (Electric motor)
- » Leather upholstery (Upper surface and base)
- » Plug socket
- » 4 casters, 2 with brakes

Dimensions W:47 L:70 H:90/130 cm

OPTIONALS



785
LECTERN

- » Brushed stainless steel and plexiglass body

Dimensions W:45 L:70 H:120 cm



780
LECTERN

- » Dual work surface
- » Brushed stainless laminate base
- » Casters

Dimensions W:54 L:55 H:115 cm



711
LECTERN

- » 2 shelves

Dimensions W:68 L:63 H:122 cm



740
LECTERN

- » Brushed stainless laminate base
- » Casters

Dimensions W:54 L:55 H:115 cm



1657
COCKTAIL TABLE

- » Foldable, mdf lam top panel
- » Rubber edge protection
- » Electrostatic powder coated tube leg

Dimensions Ø:70 H:105 cm

1652
COCKTAIL TABLE

- » Mdf lam panel
- » Rubber edge protection
- » AISI 304 stainless steel leg

Dimensions Ø:70 H:105 cm



1625
COCKTAIL TABLE

- » Mdf lam panel
- » Rubber edge protection
- » Electrostatic powder coated leg

Dimensions Ø:70 H:105 cm



1654
COCKTAIL TABLE

- » Mdf lam panel
- » Rubber edge protection
- » Electrostatic powder coated tube, foldable leg

Dimensions Ø:70 H:105 cm



1380
MOBIL BAR

- » Open cabinet with stainless steel work counter
- » Granite or acrylic solid surface countertop
- » Veneered mdf covered
- » 2 speed rails
- » 1/1 GN ice reservoir made of stainless steel
- » Heavy duty wheels

Dimensions W:85 L:180 H:115 cm



1390
BACK BAR

- » Electrostatic powder coated structure
- » 8 mm tempered glass shelves
- » 4 swivel wheels

Dimensions W:60 L:160 H:200 cm



1744

BANQUET TROLLEYS

- » Electrostatic powder coated profile structure
- » Lockable door
- » Mdf shelves
- » 4 swivel casters, 2 with brakes

Dimensions W:55 L:105 H:180 cm



1740

BANQUET TROLLEY

- » AISI 304 Stainless steel body
- » Mdf/ply covered
- » Available for glass basket
- » 4 casters, 2 with breaks

Dimensions W:61 L:120 H:100 cm



1745

CUTLERY TROLLEY

- » AISI 304 Stainless steel body
- » 6 dividers for cutlery
- » 4 casters, 2 with breaks

Dimensions W:54 L:100 H:85 cm



FOLDABLE BUFFET STANDS



FOR UNIQUE PRESENTATIONS

Otelsan folding buffet stands are designed to deliver both aesthetic appeal and practical functionality, enabling elegant presentations for your guests. Thanks to their compatible transport trolleys, the buffet stands can be easily moved to the desired location and set up quickly and effortlessly.

Users can create customized body and tabletop combinations that match the décor of the venue, ensuring a harmonious and stylish presentation. With buffet stands available in different heights, unique and visually appealing food and beverage displays can be created to enhance any event experience.



OTELSAN FOLDABLE BUFFET STANDS
FOR UNIQUE PRESENTATIONS



70x70 H:75 cm

70x70 H:90 cm

70x70 H:105 cm

1670

FOLDABLE BUFFET STAND

- » 10 mm tempered glass top
- » 30x30 mm metal profile legs



70x180 H:75/90/105 cm

1680

FOLDABLE BUFFET STAND

- » 10 mm tempered glass top
- » 30x30 mm metal profile legs



2010-T

LEG TROLLEY

- » Electrostatic powder coated profile structure
- » 15 legs capacity
- » 4 casters, 2 with brakes

Dimensions W:75 L:88 H:125 cm



2010-C

GLASS TROLLEY

- » Electrostatic powder coated profile structure
- » 15 glasses top capacity (70x70cm)
- » 4 casters, 2 with brakes

Dimensions W:65 L:86 H:105 cm



2011-TC

LEG & GLASS TROLLEY

- » Electrostatic powder coated profile structure
- » 6 glasses top and 6 legs capacity (70x180 cm)
- » 4 casters, 2 with brakes

Dimensions W:80 L:196 H:105 cm



75x75 H:75 cm

75x75 H:90 cm

75x75 H:105 cm

1687

FOLDABLE BUFFET STAND

- » Stainless steel framed laminate top
- » Double-faced and color top
- » 30x30 mm metal profile foldable legs



75x180 H:75/90/105 cm

1689

FOLDABLE BUFFET STAND

- » Stainless steel framed laminate top
- » Double-faced and color top
- » 30x30 mm metal profile foldable legs



2012

TABLA VE AYAK TAŞIMA ARABASI

- » Electrostatic powder coated profile structure
- » 5 tops and 6 legs capacity
- » 4 casters, 2 with brakes



1685

NESTING TABLE

- » Tempered 8 mm glass top
- » AISI 304 stainless steel profile legs

Dimensions W:75 L:160 H:90 cm
W:70 L:150 H:85 cm
W:65 L:140 H:80 cm

METAL FINISH OPTIONS



Polished Stainless Steel



Brushed Stainless Steel



Polished Gold PVD



Brushed Gold PVD



Brushed Rose Gold PVD



INTERNATIONAL®
OTELSAN
Otel Sanitasyon Malzemeleri Otel Ekipmanları ve Mimarlık Hizmetleri A.Ş.



RESTAURANT
EQUIPMENTS

SERVICE TROLLEYS

ELEGANT SERIE



104 MS

APPETIZER TROLLEY
(Refrigerated)

- » Cooling system with compressor
- » Thermostat with digital indicator
- » Stainless steel cooling surface
- » 10 x ¼ GN capacity
- » Ice reservoir made of stainless steel
- » Plexiglass lid
- » Drawer
- » Handle for pushing
- » 4 swivel casters , 2 with brakes

Dimensions W:59 L:108 H:106 cm

104

APPETIZER TROLLEY
(Ice Cooled)

- » Stainless steel ice cooling surface
- » 10 x ¼ GN capacity
- » Ice reservoir made of stainless steel
- » Plexiglass lid
- » Drawer
- » Handle for pushing
- » 4 swivel casters , 2 with brakes

Dimensions W:59 L:108 H:106 cm





106
FLAMBE TROLLEY

- » Upper work surface with stainless steel veneer
- » Gas cooktop WOK burner
- » An apparatus for sauce
- » Drawer
- » Stainless steel trash bin
- » Extractable serving table
- » Protective rails and handle for pushing
- » 4 swivel casters , 2 with brakes

Dimensions W:60 L:117 H:92 cm



101
SERVICE TROLLEY

- » Stainless steel profile structure
- » Wooden shelves
- » Handle for pushing
- » 4 swivel casters , 2 with brakes

Dimensions W:55 L:100 H:90 cm

107
WINE TROLLEY

- » 3 pcs. of stainless steel wine coolers
- » Bottle shelves with led lighting
- » Drawer
- » Wooden glass and bottles holder
- » Handle for pushing
- » Extractable serving table
- » 4 swivel casters , 2 with brakes

Dimensions W:55 L:109 H:93 cm



102
APPETIZER TROLLEY
(Ice Cooled)

- » Stainless steel ice cooling surface
- » 10 x ¼ GN capacity
- » Ice reservoir made of stainless steel
- » Plexiglass rolltop lid
- » Handle for pushing
- » 4 swivel casters , 2 with brakes

Dimensions W:55 L:100 H:108 cm



103
APPETIZER TROLLEY
(Refrigerated)

- » Cooling system with compressor
- » Thermostat with digital indicator
- » Stainless steel cooling surface
- » 10 x ¼ GN capacity
- » Ice reservoir made of stainless steel
- » Plexiglass rolltop lid
- » Drawer
- » Handle for pushing
- » 4 swivel casters , 2 with brakes

Dimensions W:50 L:100 H:108 cm



SERVICE TROLLEYS

DELUXE SERIE



201 MS
PASTRY TROLLEY
(Refrigerated)

- » Cooling system with compressor
- » Thermostat with digital indicator
- » Stainless steel cooling surface
- » Plexiglass lid could be used from both sides
- » Double storied pastry service module
- » Hidden led lights
- » Extractable serving table
- » Protective rails
- » Brass and chrome handles
- » 4 swivel casters , 2 with brakes

Dimensions W:54 L:103 H:135 cm

209
CHEESE & DESSERT TROLLEY
(Ice cooled)

- » Stainless steel ice cooling surface
- » Ice reservoir made of stainless steel
- » Plexiglass rolltop lid
- » Wooden shelf on plexiglass top
- » Extractable serving table
- » Handle for pushing
- » 4 swivel casters , 2 with brakes

Dimensions W:54 L:103 H:114 cm



209 MS
CHEESE & DESSERT TROLLEY
(Refrigerated)

- » Cooling system with compressor
- » Thermostat with digital indicator
- » Stainless steel cooling surface
- » Plexiglass rolltop lid
- » Wooden shelf on plexiglass top
- » Extractable serving table
- » Protective rails
- » Chrome handles
- » 4 swivel casters , 2 with brakes

Dimensions W:54 L:103 H:114 cm





203
SERVICE TROLLEY

- » Extractable serving table
- » Protective rails and handle for pushing
- » 4 swivel casters , 2 with brakes

Dimensions W:54 L:103 H:82 cm



446
FLAMBE TROLLEY

- » Upper work surface with stainless steel veneer
- » Gas cooktop WOK burner
- » 3 pcs. of stainless steel apparatus for sauce
- » Drawer
- » Protective rails and handle for pushing
- » 4 swivel casters , 2 with brakes

Dimensions W:58 L:110 H:94 cm

208
WINE TROLLEY

- » 3 pcs.of stainless steel wine coolers
- » Handle for pushing
- » Wooden glass and bottle holder
- » Extractable serving table
- » 4 swivel casters , 2 with brakes

Dimensions W:54 L:103 H:87 cm



446 FLAMBE TROLLEY OPTIONS



Gas Cooktop with 2 Burners



Electric Cooktop with 2 Burners



207
HOT SERVICE TROLLEY

- » Heating system with gel fuel
- » Protective rails and handles for pushing
- » 4 swivel casters , 2 with brakes

Dimensions W:54 L:103 H:103 cm



Tempered Glass Sneeze guard

SERVICE TROLLEYS

ACTIVE SERIE



410

SERVICE TROLLEY

- » Extractable serving table
- » Chrome handles
- » 4 swivel casters , 2 with brakes

Dimensions W:48 L:97 H:77 cm

411

CHEESE & DESSERT TROLLEY

- » Extractable serving table
- » Plexiglass rolltop lid
- » Wooden shelf on plexiglass top
- » Chrome handles
- » 4 swivel casters , 2 with brakes

Dimensions W:48 L:97 H:110 cm



412

SERVICE TROLLEY

- » 2 Drawers
- » Cabinet with two doors
- » 4 swivel casters , 2 with brakes

Dimensions W:48 L:97 H:77 cm



413
GUERIDON
 » Holder for cutlery
 » 4 swivel casters , 2 with brakes
 Dimensions W:48 L:84 H:74 cm



431
FLAMBE TROLLEY
 » Single stove with lpg
 » Special system that cut the gas automatically when the fire die down
 » An apparatus for sauce and vice shelf
 » Drawer
 » Protective rails and handle for pushing
 » 4 swivel casters , 2 with brakes
 Dimensions W:55 L:120 H:85 cm

402
SERVICE TROLLEY

- » Extractable serving table
 - » Chrome handles
 - » 4 swivel casters , 2 with brakes
- Dimensions W:50 L:97 H:77 cm



432
FLAMBE TROLLEY

- » Two stoves with lpg
 - » Special system that cut the gas automatically when the fire die down
 - » An apparatus for sauce and vice shelf
 - » Drawer
 - » Protective rails and handle for pushing
 - » 4 swivel casters , 2 with brakes
- Dimensions W:57 L:135 H:85 cm



405
SERVICE TROLLEY
 » Extractable serving table
 » 2 Drawers
 » Chrome handles
 » 4 swivel casters , 2 with brakes
 Dimensions W:50 L:97 H:77 cm

431/432 FLAMBE TROLLEY OPTIONS



Stainless Steel Work Bench



Tempered Glass Sneeze guard



Gas Cooktop Wok Burner

SERVICE TROLLEYS

CLASIC SERIE



521
WINE TROLLEY

- » 2 pcs. of ice buckets
- » Plexiglass stand for holding glasses
- » Wooden bottle holder
- » Extractable serving table
- » Protective rails and handle for pushing
- » 4 swivel casters , 2 with brakes

Dimensions W:52 L:94 H:97 cm

511
WINE TROLLEY

- » Protective rails and handle for pushing
- » 4 swivel casters , 2 with brakes

Dimensions W:65 L:120 H:85 cm



531
SERVICE TROLLEY

- » Protective rails and handle for pushing
- » 4 swivel casters , 2 with brakes

Dimensions W:65 L:120 H:85 cm



471

APPETIZER TROLLEY
(Ice Cooled)

- » Stainless steel ice cooling surface
- » 10 x ¼ GN capacity
- » Ice reservoir made of stainless steel
- » Plexiglass lid
- » Extractable serving table
- » Handle for pushing
- » 4 swivel casters , 2 with brakes

Dimensions W:60 L:105 H:105 cm



541

SERVICE TROLLEY

- » Protective rails
- » 4 swivel casters , 2 with brakes

Dimensions Ø:57 H:80 cm

471 MS

APPETIZER TROLLEY
(Refrigerated)

- » Thermostat controlled cooling system with compressor
- » Stainless steel cooling surface
- » 10 x ¼ GN capacity
- » Ice reservoir made of stainless steel
- » Plexiglass lid
- » Extractable serving table
- » Handle for pushing
- » 4 swivel casters , 2 with brakes

Dimensions W:60 L:105 H:105 cm



461

SOUP TROLLEY

- » Cheffing dish apparatus made of copper for soup service
- » Handle for pushing
- » 4 swivel casters , 2 with brakes

Dimensions W:50 L:97 H:92 cm



472 MS

APPETIZER TROLLEY
(Refrigerated)

- » Thermostat controlled cooling system with compressor
- » Stainless steel cooling surface
- » Ice reservoir made of stainless steel
- » Plexiglass rolltop lid
- » Extractable serving table
- » Handle for pushing
- » 4 swivel casters , 2 with brakes

Dimensions W:60 L:105 H:120 cm



462

SOUP TROLLEY

- » Cheffing dish apparatus made of copper for soup service
- » Handle for pushing
- » 4 swivel casters , 2 with brakes

Dimensions W:50 L:107 H:92 cm



1661

BABY CHAIR

- » Electrostatic powder coated tube structure
- » 4 swivel casters, 2 with breaks

Dimensions W:48 L:68 H:100 cm



1846

MENU STAND A2

- » Wooden frame
- » Suitable for use A2 landscape or portrait (420x594 mm)
- » Stainless steel leg and base

Dimensions W:35 L:65 H:122 cm



1663

BABY CHAIR

- » Wooden body
- » 4 swivel casters, 2 with breaks

Dimensions W:50 L:65 H:83 cm



452

SERVICE TROLLEY

Dimensions W:50 L:105 H:100 cm



453

SERVICE TROLLEY

Dimensions W:50 L:105 H:100 cm



1847

NEWSPAPER RACK

- » Wooden body
- » Electrostatic powder coated leg

Dimensions W:40 L:50 H:145 cm



650

WAITER'S STATION

- » Two drawers with 6 dividers
- » Cabinet with two doors

Dimensions W:44 L:84 H:106 cm



621

GUERIDON

- » Drawer with 6 dividers
- » 4 swivel casters, 2 with brakes

Dimensions W:42 L:80 H:74 cm

651

WAITER'S STATION

- » Two drawers with 3 dividers
- » Cabinet with door

Dimensions W:44 L:44 H:130 cm



631

GUERIDON

- » Drawer with 6 dividers
- » Cabinet with two doors
- » 4 swivel casters, 2 with brakes

Dimensions W:41 L:81 H:74 cm



652

WAITER'S STATION

- » Two drawers with 6 dividers
- » Cabinet with two doors

Dimensions W:44 L:84 H:130 cm



655

WAITER'S STATION

- » Two drawers with 6 dividers
- » Cabinet with two doors
- » 4 swivel casters, 2 with brakes

Dimensions W:50 L:84 H:91 cm

ROOM SERVICE TROLLEYS

SILENT HYGIENIC

Otelsan room service trolleys feature a durable foldable and nesting body structure for easy use and space-saving storage. Ultra-quiet wheels ensure silent movement, preventing guest disturbance even at night.

With a digital thermostat and insulated heating compartments, meals are kept at the ideal serving temperature. Removable stainless-steel shelves provide easy cleaning and high hygiene standards for efficient service.





911
ROOM SERVICE TROLLEY / ROUND
(Foldable)

- » Electrostatic powder coated profile structure
- » Folds to save space when stored
- » 4 swivel silent casters, 2 with breaks

Dimensions Ø:90 H:75/116 cm

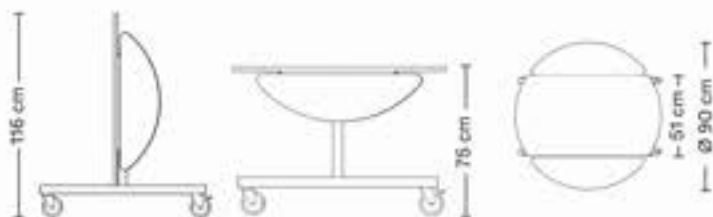

911 D
ROOM SERVICE TROLLEY / SQUARE
(Foldable)

- » Electrostatic powder coated profile structure
- » Folds to save space when stored
- » 4 swivel silent casters, 2 with breaks

Dimensions W:90 L:90 H:75/116 cm



911 O
ROOM SERVICE TROLLEY / OVAL
(Foldable)

- » Electrostatic powder coated profile structure
- » Folds to save space when stored
- » 4 swivel silent casters, 2 with breaks

Dimensions W:90 L:110 H:75/116 cm



910
ROOM SERVICE TROLLEY

- » Electrostatic powder coated tube structure
- » 4 swivel casters, 2 with breaks

Dimensions Ø:90 H:75 cm





931
HOT BOX

- » Stainless steel inner box.
- » Easy to remove and washable 1+3 Shelves.
- » Heat insulated.
- » Available for max.Ø32cm plate
- » Digital thermostat controller

Dimensions W:40 L:42 H:50 cm

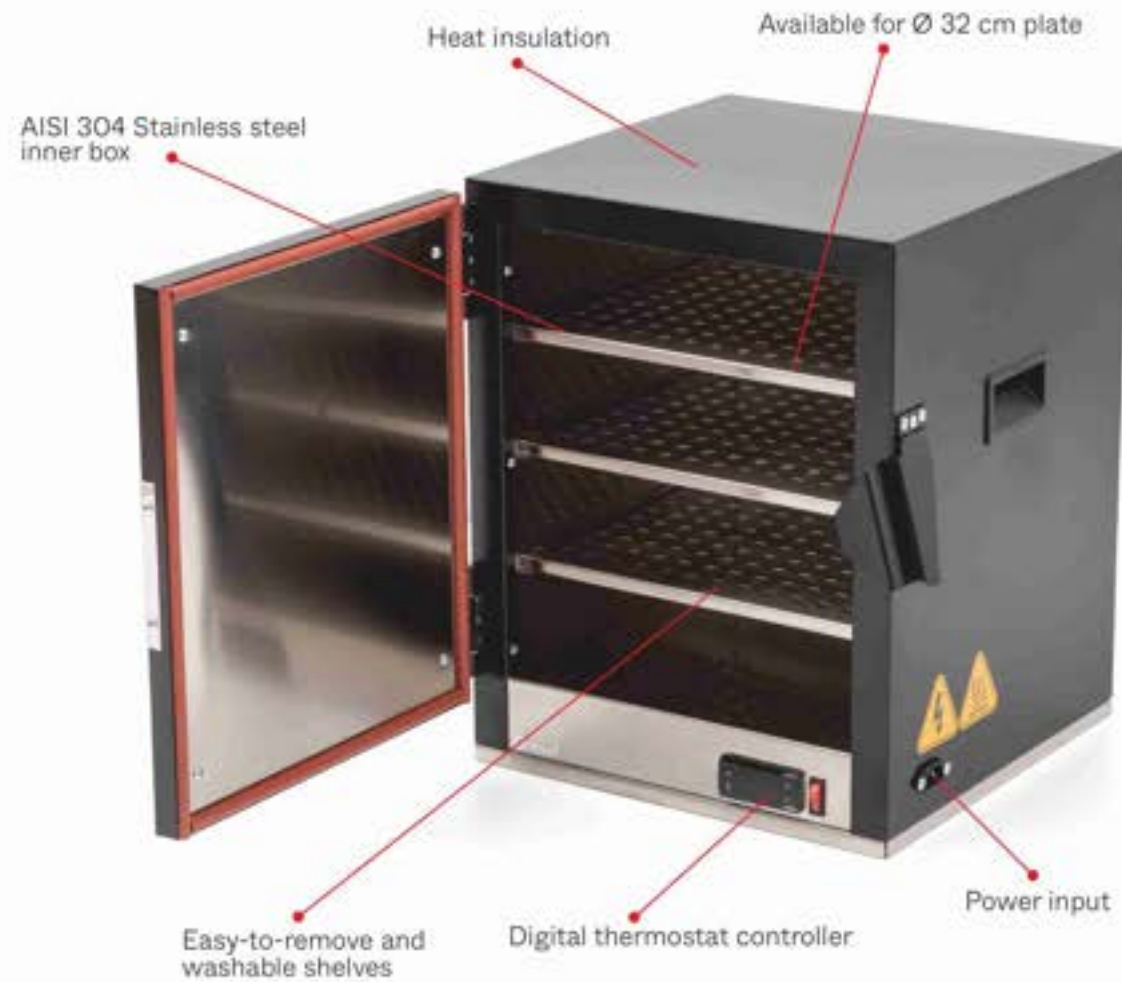

1455 P
HOT BOX STATION

- » AISI 304 Stainless steel profile structure
 - » 6 hot box capacity
 - » Master power unit has own cord and switch
- Note: Hot boxes are not included.

Dimensions W:50 L:102 H:150 cm

921
HOT BOX

- » Electrostatic powder coated body
- » Thermostat controlled 30-90°C

Dimensions W:36 L:37 H:45 cm





862
TRAY JACK
» Foldable wooden body
Dimensions W:35 L:55 H:83 cm

861
TRAY JACK
(Stainless Steel)
» Foldable, stainless steel body
Dimensions W:42 L:49 H:83 cm



850
TRAY (WOODEN)
» Massive edges and handle
» Laminate surface
Dimensions W:40 L:60 cm



1755
TRAY TROLLEY
» Electrostatic powder coated profile structure
» Mdf/ply covered
» 14 trays capacity
Dimensions are depending to tray size.

1756
TRAY TROLLEY
» Electrostatic powder coated profile structure
» Mdf/ply covered
» 28 trays capacity
Dimensions are depending to tray size.



1765
TRAY TROLLEY
» AISI 304 Stainless steel structure
» 17 capacity
Dimensions W:44 L:63 H:172 cm





1766

TRAY TROLLEY

- » AISI 304 Stainless steel structure
- » 15 pcs. 37x53cm tray capacity

Dimensions W:57 L:43 H:160 cm



1767

TRAY TROLLEY

- » AISI 304 Stainless steel structure
- » 30 pcs. 37x53cm tray capacity

Dimensions W:57 L:83 H:160 cm



1768

BASKET TROLLEY

- » AISI 304 Stainless steel structure
- » 10 pcs. basket capacity

Dimensions W:56 L:55 H:165 cm



1760

PLATE TROLLEY

- » 100 plates capacity
- » Easy change to any plate size
- » Electrostatic powder coated structure
- » Anti slip silicon stoppers
- » Handles for pushing
- » 4 swivel polyamide casters, 2 with brakes

Dimensions W:70 L:70 H:185 cm

1780

PLATE TROLLEY

- » Adjustable 6 divider
- » Available for max. Ø 32cm plate
- » According to plate diameter 250-450 capacity

Dimensions W:71 L:110 H:80 cm



1723

BASKET TROLLEY

- » AISI 304 Stainless steel body
- » 4 swivel casters, 2 with brakes

Dimensions W:55 L:55 H:90 cm



1725

KITCHEN TROLLEY

- » AISI 304 Stainless steel body
- » 4 swivel casters, 2 with breaks

Dimensions W:55 L:86 H:90 cm



1736

PLATFORM TROLLEY

- » Electrostatic powder coated structure
- » 4 swivel casters, 2 with brakes

Dimensions W:60 L:120 H:88 cm

1724

KITCHEN TROLLEY

- » AISI 304 Stainless steel body
- » 4 swivel casters, 2 with breaks

Dimensions W:55 L:86 H:90 cm



1735 P

PLATFORM TROLLEY

- » AISI 304 Stainless steel body
- » 4 casters, 2 with breaks

Dimensions W:60 L:80 H:20/90 cm



1720

KITCHEN TROLLEY

- » AISI 304 Stainless steel body
- » 4 swivel casters, 2 with brakes

Dimensions W:55 L:85 H:90 cm



1721

BOX TROLLEY

- » Electrostatic powder coated tube structure
- » 2 fixed wheels

Dimensions W:52 L:60 H:116 cm



302 MS

PASTRY TROLLEY

- » Cooling system with compressor
- » Thermostat with digital indicator
- » Perforated stainless steel cooling surface
- » Automatic defrost system
- » Two sided plexiglass lid
- » Double storied pastry service module
- » Hidden lights
- » Drawer
- » 4 swivel casters , 2 with brakes

Dimensions W:55 L:140 H:112 cm



321 MS

PASTRY DISPLAY CABINET

- » Cooling system with compressor
- » Thermostat with digital indicator
- » Automatic defrost system
- » Thermopane insulating glass
- » Hidden lights
- » Revolver shelves
- » 4 fixed casters (Hidden)

Dimensions W:66 L:66 H:193 cm

305 MS

PASTRY TROLLEY

- » Cooling system with compressor
- » Thermostat with digital indicator
- » Perforated stainless steel cooling surface
- » Automatic defrost system
- » Two sided plexiglass lid
- » Double storied pastry service module
- » Hidden lights
- » 4 swivel casters , 2 with brakes

Dimensions W:55 L:140 H:112 cm



322 MS

PASTRY DISPLAY CABINET

- » Cooling system with compressor
- » Thermostat with digital indicator
- » Automatic defrost system
- » Thermopane insulating glass
- » Hidden lights
- » Revolver shelves
- » 4 fixed casters (Hidden)

Dimensions W:66 L:130 H:193 cm





160 MS
SALAD BAR

- » Cooling system with compressor
- » Cold surface are isotable with polyurathane
- » Foldable servicebench on both sides
- » Hidden lights
- » 4 x 1/1 GN capacity
- » 4 swivel casters (hidden)

Dimensions W:62/110 L:142 H:90/150 cm



140 MS
SALAD BAR

- » Cooling system with compressor
- » Cold surface are isotable with polyurathane
- » Foldable servicebench on both sides
- » 4 x 1/1 GN capacity
- » Hidden lights
- » 4 swivel casters (hidden)

Dimensions W:73/114 L:156 H:90/150 cm

110 MS
SALAD BAR

- » Cooling system with compressor
- » Cold surface are isotable with polyurathane
- » Granite bench
- » 4 x 1/1 GN capacity
- » Hidden lights
- » 4 fixed casters (hidden)

Dimensions W:97 L:183 H:90/150 cm



130 MS
SALAD BAR

- » Cooling system with compressor
- » Plexiglass lid serviceable from both sides
- » Cold surface are isotable with polyurathane
- » Foldable bench on two sides
- » Hidden lights
- » 4 x 1/1 GN capacity
- » 4 swivel casters (hidden)

Dimensions W:70/105 L:155 H:90/130 cm



BUFFET STATIONS

TREND SERIE



MOBILE AESTHETICS

Otelsan buffet units are designed for hotel breakfast, lunch, and dinner services, offering custom sizes and designs that match your interior decoration.

Equipped with advanced heating and cooling systems, they ensure food is served in compliance with HACCP standards. Optional sneeze guards provide enhanced hygiene and protection for guests.

Thanks to concealed wheels, the units can be easily moved by a single person, allowing convenient floor cleaning and flexible layout changes within the hall. Integrated cabinets and drawers offer practical storage for tableware and service equipment.



TREND 312

NOTR UNIT

- » Granite counter
- » Stainless steel base
- » 20x40x1,5mm powder coated chassis
- » Heavy-duty, hidden wheels

Dimensions W:70 L:160 H:90 cm

TREND 313

COLD UNIT

- » Granite counter
- » Granite surface cooling
- » 220 W 50 HZ, R404 cooling gas
- » Digital temperature display
- » Glass sneezeguard
- » Led lighting
- » Stainless steel base
- » 20x40x1,5mm powder coated chassis
- » Heavy-duty, hidden wheels

Dimensions W:70 L:160 H:90/145 cm





TREND 314

SOUP UNIT

- » Granite counter
- » 1 round roll-top chafing dish for soup (6 lt)
- » Stainless steel bowl heating reservoir
- » Glass sneeze guard
- » Led lighting
- » Stainless steel base
- » 20x40x1,5mm powder coated chassis
- » Heavy-duty, hidden wheels

Dimensions W:70 L:160 H:90/145 cm



TREND 316

HOT UNIT

- » Granite counter
- » 3 pcs. round roll-top chafing dish
- » Glass sneeze guard
- » Led lighting
- » Stainless steel base
- » 20x40x1,5mm powder coated chassis
- » Heavy-duty, hidden wheels

Dimensions W:70 L:195 H:90/145 cm



TREND 315

HOT UNIT

- » Granite counter
- » 2 pcs. 1/1 GN roll-top chafing dish
- » Glass sneeze guard
- » Led lighting
- » Stainless steel base
- » 20x40x1,5mm powder coated chassis
- » Heavy-duty, hidden wheels

Dimensions W:70 L:160 H:90/145 cm

TREND 317

HOT UNIT

- » Granite counter
- » 4 pcs. 1/1 GN roll-top chafing dish
- » Glass sneeze guard
- » Led lighting
- » Stainless steel base
- » 20x40x1,5mm powder coated chassis
- » Heavy-duty, hidden wheels

Dimensions W:130 L:160 H:90/145 cm





TREND 318

BREAD UNIT

- » Granite counter
- » Drawer and cabinet
- » Bread shelves
- » Stainless steel base
- » 20x40x1,5mm powder coated chassis
- » Heavy-duty, hidden wheels

Dimensions W:70 L:160 H:90/150 cm



TREND 320

PLATE UNIT

- » Granite counter
- » Plate dispenser available for Ø24-32 cm plate (50 pcs. capacity)
- » Stainless steel base
- » 20x40x1,5mm powder coated chassis
- » Heavy-duty, hidden wheels

Dimensions W:70 L:70 H:90 cm



TREND 319

BEVERAGE UNIT

- » Granite counter
- » Cabinet
- » Stainless steel base
- » 20x40x1,5mm powder coated chassis
- » Heavy-duty, hidden wheels

Dimensions W:70 L:160 H:90 cm

TREND 321

PLATE UNIT

- » Granite counter
- » Stainless steel base
- » 20x40x1,5mm powder coated chassis
- » Heavy-duty, hidden wheels

Dimensions W:70 L:95 H:90 cm



INTERNATIONAL®
OTELSAN
Otelsan Buklet Malzemeleri Otel Ekipmanları ve Mimarlık Hizmetleri A.Ş.

www.otelsan.com.tr

INTERNATIONAL® OTELSAN

Otelsan Buklet Malzemeleri Otel Ekipmanları ve Mimarlık Hizmetleri A.Ş.

OTELSAN A.Ş.

Sales & Export Office

+90 224 250 27 00

+90 850 885 55 33

export@otelsan.com.tr

Üçevler District, Coşkun Street
İnci Plaza, Floor: 1, Office: 10
Nilüfer / Bursa / Türkiye